

THE

proko
electronics

PTR-II

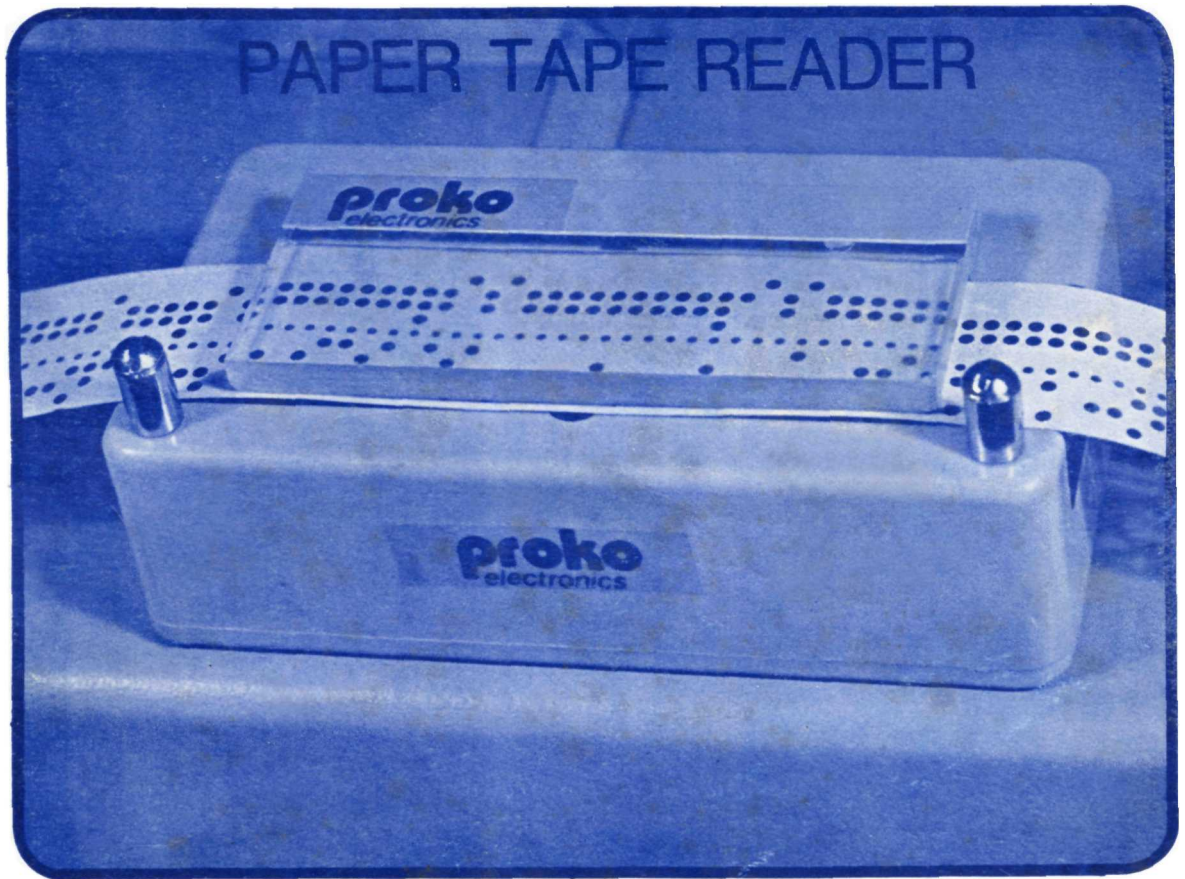

FEATURES

- LOW COST
- POCKET SIZE
- RELIABLE
- TTL COMPATABLE
- SIMPLE TO OPERATE

USES

- BACK UP FOR DATA INPUT
- TROUBLE SHOOTING AID
- HOBBIEST INPUT DEVICE
- PAPER TAPE TO CASSETE
- SYSTEM BOOTSTRAP

© 1976

proko electronics  "EMPIRICAL
ENGINEERING"

INTRODUCTION

The new, high speed, low-cost paper tape reader from Proko Electronics means a more convenient and economical way to load commercially available programs. This unit has no moving parts, and can input data nearly as fast as you can pull it through. The PTR II is ideally suited for loading basic, assembler, monitors, etc., into your machine. This unit can interface to any computer with an eight-bit parallel input port. The paper tape can be removed or inserted from either end or from the side of the unit at any place in the tape.

Some fairly fancy mechanical assembly is required in this kit, the first place to look for missing bits is in poor optical alignment.

Read this manual carefully as you assemble the PTR II and refer to it if you encounter difficulties.

PARTS LIST

- (1) ABS plastic enclosure
- (1) acrylic lens piece
- (1) 25-pin type D connector with pins
- (1) P.C. Board
- (8) R_1 - R_8 Value determined by kit _____K
- (1) R_9 Value determined by kit 100 K
- (1) R_{10} - $4.7K^{1/4}W$
- (1) C1 - 0.01 or 0.005uf capacitor
- (1) C2 - 18uf tantilum 10V capacitor
- (1) 18-pin socket
- (2) 14-pin socket
- (1) 3 feet. 12-conductor ribbon cable
- (1) IC-1 optical sensor array
- (2) IC-2, IC-3 74LS14
- (4) 4-40 machine screws
- (2) 6-32 screws with washers
- (2) spacers

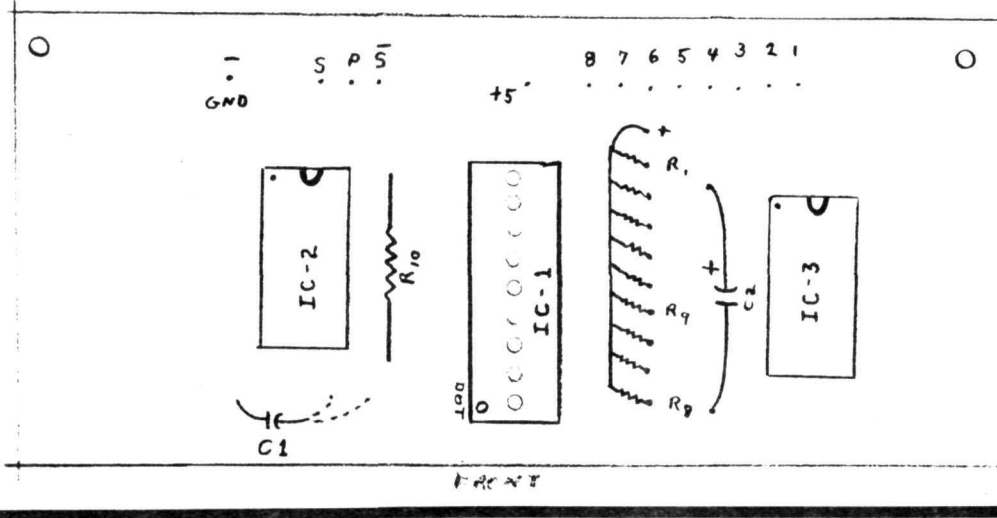

-PRINTED CIRCUIT BOARD ASSEMBLY-

- ◇ Check kit contents against parts list.
- ◇ Insert two 14-pin and one 18-pin sockets into the component side of the board with the pin "1" index toward the upper left of the board. (The component side is the side on which there is no copper). Solder.
NOTE: Keep soldering tip clean to prevent rosin and sludge from being deposited on traces. Wipe tip frequently on a damp cloth.
- ◇ Observing polarity, insert and solder the tantalum capacitor, C2.
- ◇ Insert and solder capacitor C1 and resistor R₁₀.
- ◇ Insert and solder resistors R₁ through R₉. Keep in mind R₉ is fourth from the front. These resistors stand vertically on the board and are soldered to a 5V bus wire
- ◇ Separate each conductor of the ribbon cable approximately 1/2 inch.

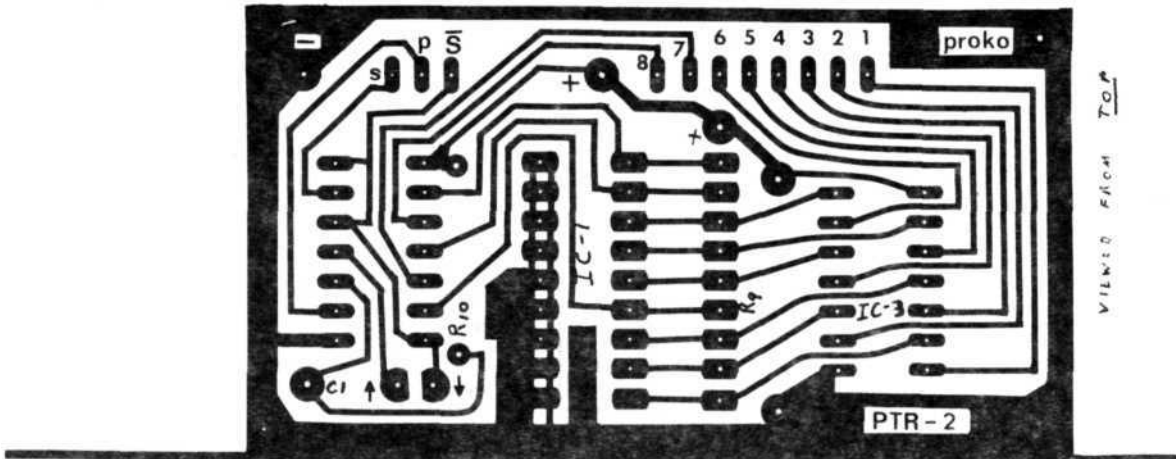

- ◇ With a pair of wire strippers, strip the insulation back 1/8th of an inch. Carefully tin each wire.
- ◇ Solder the first 11 wires of the ribbon cable to the PC board, omitting "S" and "S̄". (Pads #1 thru #8, "P", "+" and "-")
- ◇ Solder the remaining wire to the "S̄" pad.
- ◇ Insert IC-2 and IC-3 with Pin 1 indexed toward the rear left.
- ◇ Insert IC-1 carefully bending the leads out so they properly align with the IC socket.
NOTE: The orientation of the optical sensor is important. Be sure the white spot is on the side away from resistors R₁-R₉
- ◇ It will be helpful if you lift IC-1 slightly from it's socket. This will allow it to position itself during the mechanical assembly.(lift it only 1/16" or so)

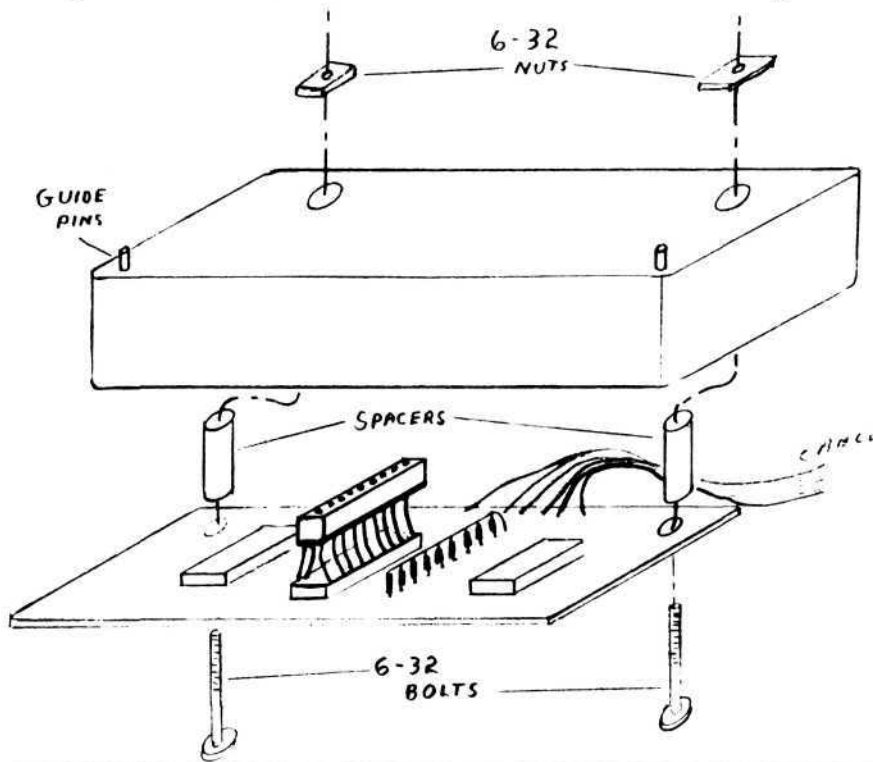

MECHANICAL ASSEMBLY

- ◇ Work under a bright light.
- ◇ After P.C. board is assembled, install it in the PTR II housing without the acrylic lens piece, using, the two 6-32 nuts instead.
- ◇ With the readhead setting in the proper location, temporarily hold the black mask over the assembly and check for alignment with both the guide pins and the individual cells of the readhead. Loosen bolts and readjust if necessary.

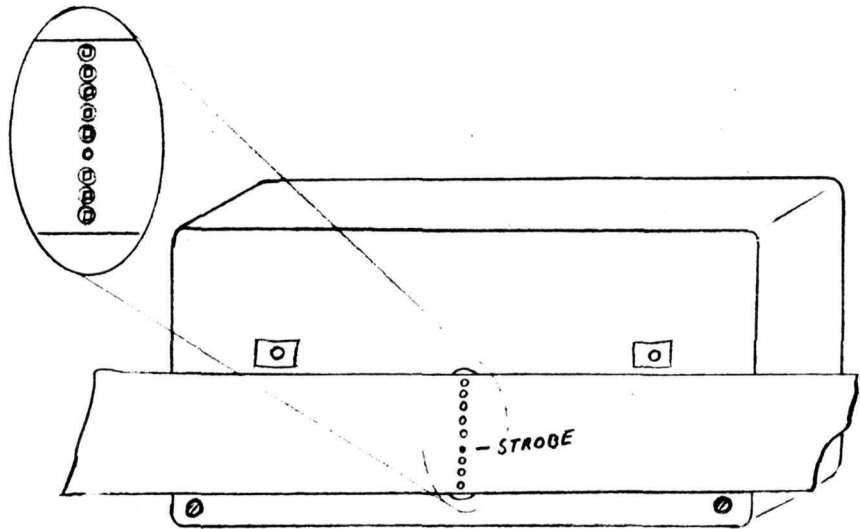

- ◇ When you are certain good alignment is possible, peel the backing from the mask and gently (without stretching) apply from the center out, and recheck for alignment.

- ◇ Tuck the ends of the mask inside of the box.

- ◇ It is a good idea at this point to try an actual piece of paper tape held over the black mask and over the readhead. Note that the strobe hole is smaller and nearer the bottom.

- ◇ If alignment seems difficult, it may be necessary to rebend the leads of the readhead or lift it slightly from its socket.

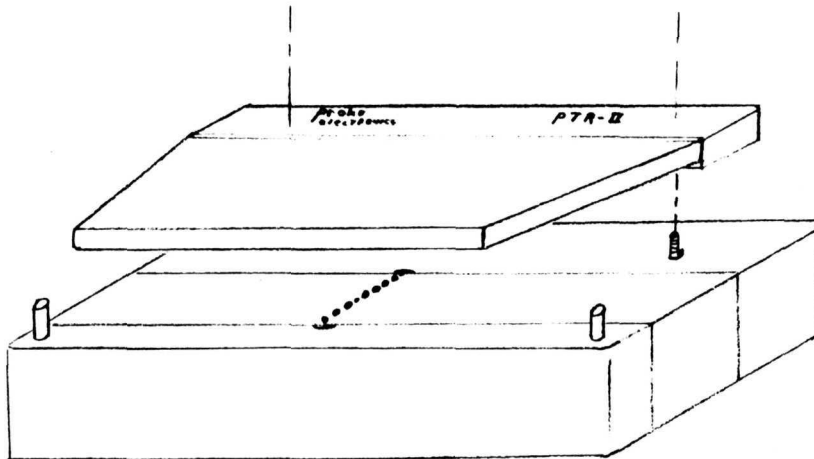

- ◇ Holding the bolts in place, remove the two 6-32 nuts and install the lens piece. Don't tighten bolts yet.

- ◇ Try the test tape again and position the lens piece for good alignment and free tape travel. Tighten the two bolts.

- ◇ Install the rear cover

* * * *

When unit is in use, dirt and dust may accumulate under the lens. For this reason, it is a good idea to periodically remove the lens piece and clean the mask with a damp cloth.



25 PIN "D" CONNECTOR

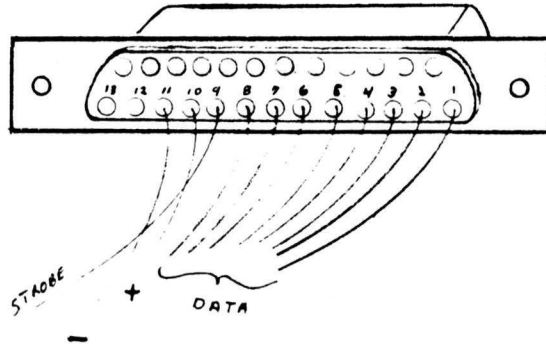

- ◇ If you are connecting the PTR II to an existing parallel port, you should wire the "D" connector to mate with that port (be sure to provide 5VDC). If not, the following connection can be made.
- ◇ Now you are ready to solder the 25-pin connector to the ribbon cable. It is suggested that Bit 1 be soldered to Pin 1 of the connector and Bit 2 to Pin 2, etc. Solder the pin to the wire first, then push the pins into the connector.
- ◇ Solder Pin 9 to the strobe of your choice.
See page 10
- ◇ Solder Pin 10 to plus 5V and Pin 11 to ground from the PTR II PC board (wires #10 & #11)
NOTE: The 5V supply must come from the I/O board to the PTR II, so provisions must be made to connect power to the PTR II.

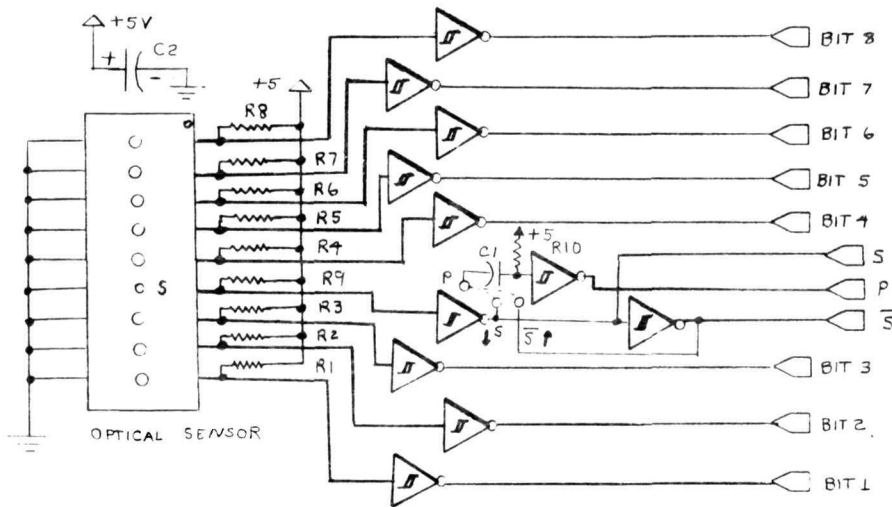

The heart of the PTR-II is a precision 9-element silicon photo readhead. The elements of this optical sensor have been specially matched to greatly increase its reliability and reduce the circuitry.

Resistors R_1 through R_8 determine the sensitivity for each element. Resistor R_9 is larger to compensate for the reduced light from the strobe. The values for resistors R_1 - R_9 are supplied to match the particular sensitivity of each readhead.

FINAL CHECK AND TROUBLE-SHOOTING

Your PTR II is now ready for testing.

Be certain the unit is clean and free of solder shorts. Most of the difficulties encountered with peripherals can be traced to software or a logical-hardware error. Be certain the input port is addressed correctly and that the strobe or status is used the way your software thinks it should be.

Make sure +5v and ground are properly connected to the I/O connector and I/O board.

There are four possible strobe outputs on the PTR II. They are:

- 1) strobe (a TTL level)
- 2) strobe
- 3) pulse \uparrow (a short, negative pulse on the leading edge of the sprocket hole)
- 4) pulse \downarrow (as above but on the trailing edge)

Most systems use strobe.

The strobe and strobe outputs are brought to the edge of the PTR II P.C. board. The pulse is output on pad "P" (see Fig. 2). The direction and length of the pulse is determined by C1 and where it is placed. The larger its value the longer the pulse.

If the PTR II is to be used with an 8080 system, the following section may be some help.



Make sure +5V and ground are properly connected to the I/O connector and I/O card.

The first step in testing is to get the data displayed.

You might want to try the following method of input for the 8080. This modification would be wired from a spare nand gate on the I/O card.

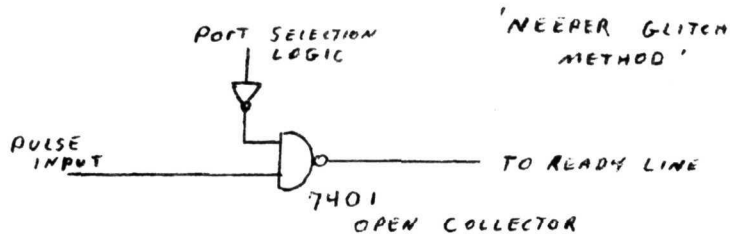

When the port device is selected, the input strobe goes low causing the ready line to go low stopping the processor. The processor goes into a wait state. Only when a signal is applied to the pulse input does the processor run again.

Load and run the following program, where xx is the input port number.

```

0000    DBxx    LOOP: INPUT  PTRII    ; ACC=DATA
0002    2F      CMA
0003    D3FF    OUT        ;FRONT PANEL
0005    C30000 JMP        LOOP

```

**THIS ROUTINE DISPLAYS CONTINUOUSLY, THE DATA
FROM THE PTR II...**

Obtain a test tape. Connect the modification shown above.

If you do not desire to use the "Neeper-Glitch" method, you can use a separate port for status. The software would look something like this:

```
input  IN,  strobe
      CPI  2
      JNZ  input
      IN   DATA
      OUT  front panel
      JMP  input
```

If you do not own an IMSAI 8080, you can output to a terminal or perhaps some test lamps tied to an output port..

The light is somewhat critical. A small study lamp approximately 15W is best. For best results move the light closer to the sensor so all bits are on on the data bus lights. Now back off the lamp just until the bits with holes in the paper tape are on.

WARNING: With too strong a light and yellow paper tape, the light may go through the tape and cause error. Therefore, for best results and high reliability, the above test is recommended for each program loaded from yellow or light green tape.

If you should find that one or two bits refuse to change, try reversing IC-2 and IC-3.